

AquaSHIELD[®]

PROTECTIVE ENCLOSURES

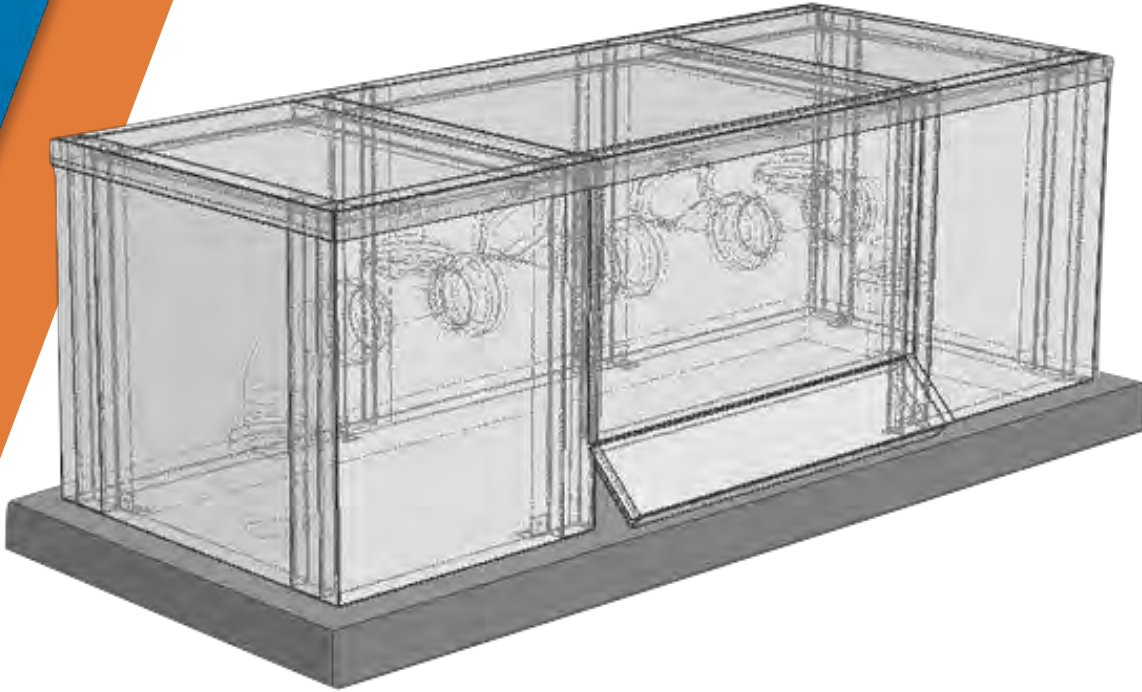

When you want a quality protective enclosure . . . turn to *AquaSHIELD*.

The Top 4 Things you need to know about AquaSHIELD:

#1 TIME-TESTED

AquaSHIELD has been manufacturing enclosures for over 20 years and continues to deliver products all across the country with an extremely high customer satisfaction.

#2 SHORT LEAD-TIMES

When you need a protective enclosure quickly, turn to *AquaSHIELD*! We can ship most standard orders within 1 week and custom orders within 2 weeks!

#3 QUALITY AND EASE

AquaSHIELD enclosures are manufactured out of marine grade aluminum giving them long term durability. They are all designed for quick and easy installation (no subassembly required), and have proven time and time again to provide freeze and vandal protection for outdoor assemblies.

#4 AFFORDABLE

AquaSHIELD offers a competitively priced product that is ASSE 1060 Class I, II, III certified giving you everything you need in a protective enclosure.

SECTIONS

1. (1"-2") IN-LINE VALVE ENCLOSURES
2. (3"-10") IN-LINE VALVE ENCLOSURES
3. (3"-10") N-PATTERN VALVE ENCLOSURES
4. HEATERS / HEAT CABLES / ALARMS
5. MISCELLANEOUS

Section 1

1” and 2” In-Line Valve Enclosures

SUBMITTAL DATA
SHEET (888) 345-6675
(501) 791-1800
Fax (501) 791-1801
www.aquashieldenclosures.com

BFP1-S SERIES
BFP2-S SERIES

ENCLOSURE FEATURES

- Easy Access
- Removable Top and Front Panel
- Lockable for Vandal Protection
- Freeze Protection (-30F)
- No subassembly required
- Oversized Drains at Enclosure Grade
- Structurally Rigid Insulation
- Simple Installation
- Mounting Hardware Included



STANDARDS & CODES

- ASSE 1060
- ASTM B209
- OSHA 1910

PRODUCT MATERIALS

- .050 MILL FINISHED MARINE GRADE ALUMINUM
- POLYISOCYANURATE INSULATION 1.5" THICK (10.0 R- VALUE)

The backflow enclosure shall be ASSE 1060 certified and shall provide freeze and vandal protection for backflow preventers installed outside and above ground. Materials shall be (.050/18 ga.) mill finished aluminum bonded to a unicellular non-wicking polyisocyanurate foam core insulation. Insulation shall be 1.5" thick (R10) and have a heavy black reinforced fiber on each side. Drain shall be insulated and sized to accommodate maximum discharge of the backflow preventer valve and remain closed except during discharge of the backflow valve. The enclosure shall have full access for testing and servicing of the backflow preventer with strategically placed lockable access panels. Enclosure shall be anchored to a concrete pad within the enclosure with masonry anchors.

Heat, when required (ASSE 1060 Class I), shall be a 120V/1P self-regulating heat cable. Heat cable shall be UL or ETL listed and sized to maintain freeze protection of the backflow preventer with an outside temperature of -30°F. Heat cable shall have a male receptacle plug for easy power connection. Power source shall be a ground fault interrupter receptacle supplied and installed by others. Electrical power source shall be installed in accordance with

MODEL NUMBER	ENCLOSURE DESCRIPTION	INSIDE DIMENSIONS			OUTSIDE DIMENSIONS			CONCRETE PAD DIMENSIONS			SHIPPING WEIGHT
BFP1-S	1" W/STRAINER	30"L	10"W	22"H	33"L	13"W	24"H	45"L	25"W	6"T	45#
BFP2-S	2" W/STRAINER	43"L	14"W	28"H	46"L	17"W	30"H	58"L	29"W	6"T	65#



Outdoor Enclosure Specifications Model BFP1-S & BFP2-S

1 GENERAL

1.1 WORK INCLUDED

- A. Provide a manufactured outdoor enclosure for backflow prevention assembly.

1.2 QUALITY ASSURANCE

- A. Qualifications: The manufacturer of the outdoor enclosure shall be a company specializing in the field of manufacturing of such enclosures with at least ten (10) years of successful field installations and be ASSE 1060 Seal certified.

1.3 REFERENCES

- A. ASSE 1060-Performance Requirements for Outdoor Enclosures for Backflow Prevention Assemblies.
- B. ASTM B209

1.4 ACCEPTABLE MANUFACTURERS

- A. **AquaSHIELD** or Engineer approved equivalent.

2 PRODUCTS

2.1 MODEL NO. & SIZE

- A. Model No. shall be BFP__-S
- B. Inside dimensions shall be __"L x __"W x __"H (+ or - 1/2")

2.2 MATERIALS OF FABRICATION

- A. Materials for exterior walls shall be 5052-H32 aluminum (.050/18 gauge) and shall comply with ASTM B209. The aluminum shall have a standard mill finish.
- B. Insulation shall be a closed cell polyisocyanurate foam core laminated to heavy black glass fiber reinforced facers on each side. The insulation shall have the following properties:
 - R-Value - 10.0
 - Dimensional Stability - 2% Linear Change
 - Compressive Strength - 20 psi and 25 psi
 - Product Density - Nominal 2.0 pcf
 - Water Absorption - <1% By Volume
 - Service Temperature - (-100°F to +250°F)
 - Moisture Vapor Transmission - < One (1) Perm
 - Flame Spread - 25**
 - Insulation shall be 1.5" thick
- C. Adhesive shall be Hilti brand Product No. CA-3200 and shall have the following features:
 - Bonds foam products
 - Water resistant bond
 - Stays resilient
 - Will not freeze
 - Freeze/thaw stable
 - Water resistant

2.3 COMPONENTS

- A. The enclosure shall be constructed of 5052-H32 (.050/18 gauge) mill finish marine grade aluminum ASTB B209 outside with insulation 1.5" thick (10.0 "R" value) on the inside.
- B. The above components shall be securely bonded to form a composite panel.
- C. The exterior of the enclosure shall have a protective PVC masking to protect the mill finish. The protective masking shall be removed by the customer immediately after installation of the enclosure.
- D. The enclosure shall be fully assembled by the manufacturer.
- E. The top shall be removable to provide access to the BFP and shall be attached to the enclosure by aluminum clasp.
- F. The front panel shall be removable to provide access to the BFP and shall slide over the side walls from the top of the enclosure and held in place by the top.
- G. The enclosure shall be lockable with pad lock furnished by the customer.
- H. The backflow valve shall be protected inside the enclosure.
- I. Drain relief panel for the enclosure shall be constructed of same said materials as wall panels and be located in the end wall of the enclosure.
- J. Drain relief panel shall have a stainless steel hinge and stainless steel spring as a positive means of closure after water discharge to prevent the intrusion of outside air, debris and small animals.

2.4 HEATING EQUIPMENT

- A. Enclosure shall not offer freeze protection without installation of heating equipment designed and provided by the manufacturer.
- B. Heating equipment designed and provided by the manufacturer shall provide freeze protection with an external temperature as low as -34°C (-30°F).

2.5 INSTALLATION HARDWARE

- A. Concrete anchors shall be Hilti Hit type and provided by the manufacturer.
- B. Masonry drill bit and screw chuck shall be provided by the manufacturer.

2.6 INSTALLATION

- A. Enclosure shall be assembled per manufacturer's instructions provided with enclosure.
- B. Enclosure shall be mounted to concrete pad per manufacturer's instructions.
- C. Pad size shall be ___"L x ___"W x 6"T.

**INSTALLATION
INSTRUCTIONS**

BFP1-S, BFP2-S

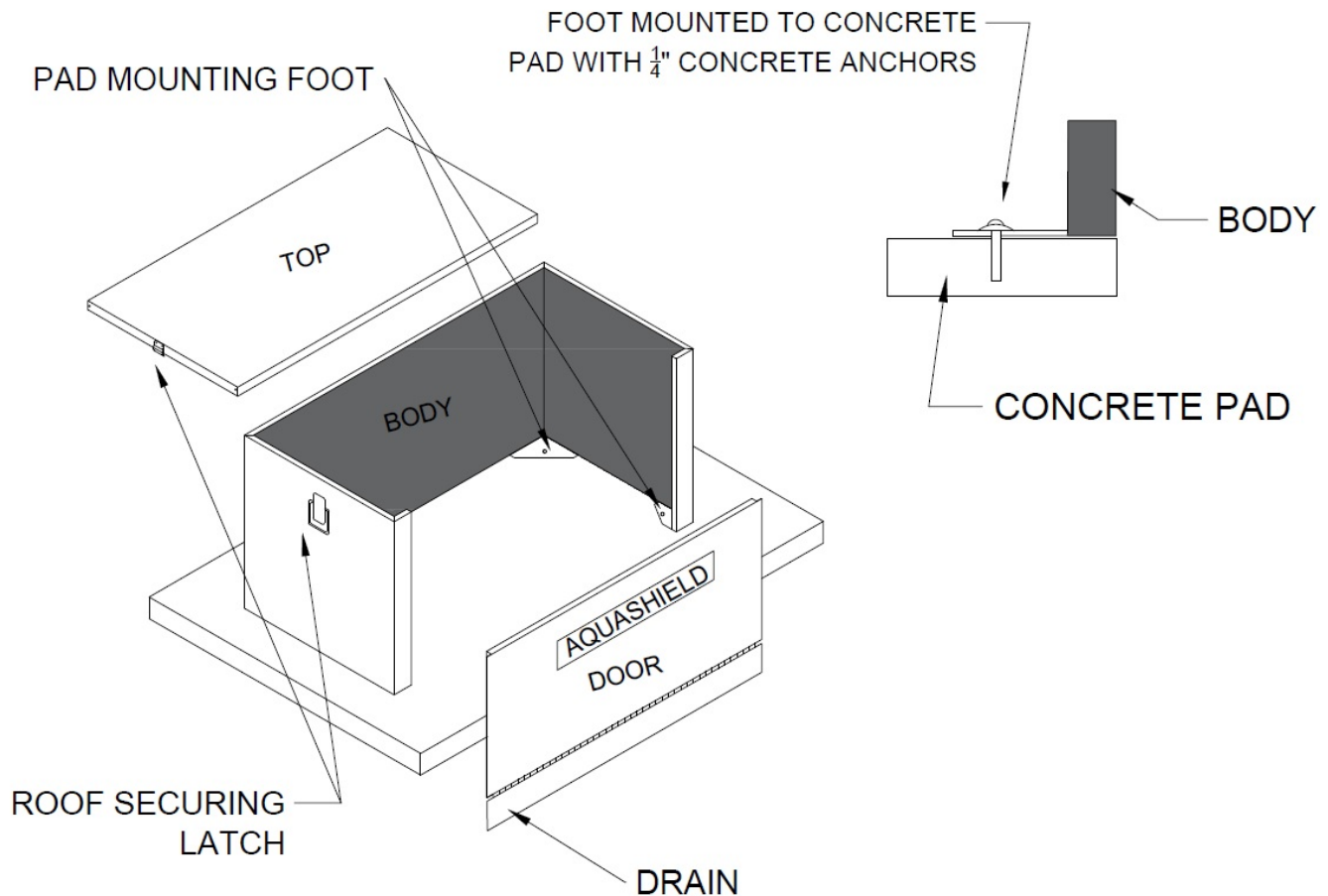

ENCLOSURE ASSEMBLY INSTRUCTIONS

1. Provide a concrete mounting pad according to the "Mounting Pad Preparation" sheet.
2. Remove top from the enclosure and set the enclosure around the BFP.
3. Inside the enclosure, mark or drill the concrete pad through the holes of the mounting angle bracket.
4. Remove the enclosure and drill the marked holes with the 1/4" masonry bit provided.
5. Set the enclosure in place and secure the enclosure with the masonry anchors provided.
6. Install heat cable per manufacturer's instructions. **Note: Provide GFI receptacle and follow all applicable electrical codes and regulations.**
7. Set top on enclosure and fasten hasp. For locked vandal protection, padlocks can be installed on the hasp.
8. Remove the protective plastic film from the enclosure. **Note: Failure to remove the plastic will cause damage to the exterior finish of the enclosure.**



MOUNTING PAD PREPARATION BFP1-S, BFP2-S

MODEL NUMBER	ENCLOSURE DESCRIPTION	INSIDE DIMENSIONS			OUTSIDE DIMENSIONS			CONCRETE PAD DIMENSIONS			SHIPPING WEIGHT
BFP1-S	1" W/STRAINER	30"L	10"W	22"H	33"L	13"W	24"H	45"L	25"W	6"T	45#
BFP2-S	2" W/STRAINER	43"L	14"W	28"H	46"L	17"W	30"H	58"L	29"W	6"T	65#

- Using the chart above, provide a concrete pad 6" thick centered around the BFP device.
 - Provide expansion material around the BFP risers.
 - Place electrical conduit in pad if heat is required, before concrete is poured.
 - Finish concrete level and smooth. Allow concrete to cure before setting enclosure.
 - Electrical power source must comply with all local and national codes.

Section 2

3” to 10” In-Line Valve Enclosures

SUBMITTAL DATA SHEET
(888) 345-6675
(501) 791-1800
Fax (501) 791-1801
www.aquashieldenclosures.com

BFP3 SERIES
3" IN-LINE VALVE

ENCLOSURE FEATURES

- Easy Access
- Removable Top and Panels
- Lockable for Vandal Protection
- Freeze Protection (-30F)
- No subassembly required
- Oversized Drains at Enclosure Grade
- Structurally Rigid Insulation
- Simple Installation
- Mounting Hardware Included



STANDARDS & CODES

- ASSE 1060
- ASTM B209
- OSHA 1910

PRODUCT MATERIALS

- .050 MILL FINISHED MARINE GRADE ALUMINUM
- POLYISOCYANURATE INSULATION 1.5" THICK (10.0 R- VALUE)

The backflow enclosure shall be ASSE 1060 certified and shall provide freeze and vandal protection for backflow preventers installed outside and above ground. Materials shall be (.050/18 ga.) mill finished aluminum bonded to a unicellular non-wicking polyisocyanurate foam core insulation. Insulation shall be 1.5" thick (R10) and have a heavy black reinforced fiber on each side. Drain shall be insulated and sized to accommodate maximum discharge of the backflow preventer valve and remain closed except during discharge of the backflow valve. The enclosure shall have full access for testing and servicing of the backflow preventer with strategically placed lockable access panels. Enclosure shall be anchored to a concrete pad within the enclosure with masonry anchors.

Heat, when required (ASSE Class I), shall be a thermostatically controlled 120V/1PH fan forced heater. Heater shall be UL or ETL listed and sized to maintain +40°F inside the enclosure with an outside temperature of -30°F. Heater shall have a six-foot cord and plug for easy receptacle connection. Power source shall be a ground fault interrupter receptacle supplied and installed by others. Electrical power source shall be installed in accordance with all state and local codes.

MODEL NUMBER	ENCLOSURE DESCRIPTION	INSIDE DIMENSIONS			OUTSIDE DIMENSIONS			CONCRETE PAD DIMENSIONS			SHIPPING WEIGHT
BFP3-N	2 DOOR PANEL	74"L	24"W	44"H	77"L	27"W	47"H	89"L	39"W	6"T	185#
BFP3-NS	2 DOOR PANEL	84"L	24"W	44"H	87"L	27"W	47"H	99"L	39"W	6"T	215#
BFP3-O	2 DOOR PANEL	74"L	24"W	55"H	77"L	27"W	57"H	89"L	39"W	6"T	215#
BFP3-OS	2 DOOR PANEL	84"L	24"W	55"H	87"L	27"W	57"H	99"L	39"W	6"T	225#

SUBMITTAL DATA SHEET

(888) 345-6675

(501) 791-1800

Fax (501) 791-1801

www.aquashieldenclosures.com

BFP4 SERIES
4" IN-LINE VALVE

- ENCLOSURE FEATURES**
- Easy Access
 - Removable Top and Panels
 - Lockable for Vandal Protection
 - Freeze Protection (-30F)
 - No subassembly required
 - Oversized Drains at Enclosure Grade
 - Structurally Rigid Insulation
 - Simple Installation
 - Mounting Hardware Included



- STANDARDS & CODES**
- ASSE 1060
 - ASTM B209
 - OSHA 1910

- PRODUCT MATERIALS**
- .050 MILL FINISHED MARINE GRADE ALUMINUM
 - POLYISOCYANURATE INSULATION 1.5" THICK (10.0 R- VALUE)

The backflow enclosure shall be ASSE 1060 certified and shall provide freeze and vandal protection for backflow preventers installed outside and above ground. Materials shall be (.050/18 ga.) mill finished aluminum bonded to a unicellular non-wicking polyisocyanurate foam core insulation. Insulation shall be 1.5" thick (R10) and have a heavy black reinforced fiber on each side. Drain shall be insulated and sized to accommodate maximum discharge of the backflow preventer valve and remain closed except during discharge of the backflow valve. The enclosure shall have full access for testing and servicing of the backflow preventer with strategically placed lockable access panels. Enclosure shall be anchored to a concrete pad within the enclosure with masonry anchors.

Heat, when required (ASSE Class I), shall be a thermostatically controlled 120V/1PH fan forced heater. Heater shall be UL or ETL listed and sized to maintain +40°F inside the enclosure with an outside temperature of -30°F. Heater shall have a six-foot cord and plug for easy receptacle connection. Power source shall be a ground fault interrupter receptacle supplied and installed by others. Electrical power source shall be installed in accordance with all state and local codes.

MODEL NUMBER	ENCLOSURE DESCRIPTION	INSIDE DIMENSIONS			OUTSIDE DIMENSIONS			CONCRETE PAD DIMENSIONS			SHIPPING WEIGHT
BFP4-N	2 DOOR PANEL	88"L	28"W	44"H	91"L	31"W	46"H	103"L	43"W	6"T	225#
BFP4-NS	2 DOOR PANEL	102"L	28"W	44"H	105"L	31"W	46"H	117"L	43"W	6"T	385#
BFP4-O	2 DOOR PANEL	88"L	28"W	54"H	91"L	31"W	56"H	103"L	43"W	6"T	435#
BFP4-OT	2 DOOR PANEL	95"L	40"W	64"H	98"L	43"W	66"H	110"L	55"W	6"T	450#
BFP4-OS	2 DOOR PANEL	102"L	28"W	54"H	105"L	31"W	56"H	117"L	43"W	6"T	450#
BFP4-NA	2 DOOR PANEL	55"L	35"W	45"H	58"L	38"W	48"H	70"L	50"W	6"T	290#
BFP4-OA	2 DOOR PANEL	55"L	45"W	45"H	58"L	48"W	48"H	70"L	60"W	6"T	315#

SUBMITTAL DATA SHEET
(888) 345-6675
(501) 791-1800
Fax (501) 791-1801
www.aquashieldenclosures.com

BFP6 SERIES

6" IN-LINE VALVE

- ENCLOSURE FEATURES**
- Easy Access
 - Removable Top and Panels
 - Lockable for Vandal Protection
 - Freeze Protection (-30F)
 - No subassembly required
 - Oversized Drains at Enclosure Grade
 - Structurally Rigid Insulation
 - Simple Installation
 - Mounting Hardware Included



- STANDARDS & CODES**
- ASSE 1060
 - ASTM B209
 - OSHA 1910

- PRODUCT MATERIALS**
- .050 MILL FINISHED MARINE GRADE ALUMINUM
 - POLYISOCYANURATE INSULATION 1.5" THICK (10.0 R- VALUE)

The backflow enclosure shall be ASSE 1060 certified and shall provide freeze and vandal protection for backflow preventers installed outside and above ground. Materials shall be (.050/18 ga.) mill finished aluminum bonded to a unicellular non-wicking polyisocyanurate foam core insulation. Insulation shall be 1.5" thick (R10) and have a heavy black reinforced fiber on each side. Drain shall be insulated and sized to accommodate maximum discharge of the backflow preventer valve and remain closed except during discharge of the backflow valve. The enclosure shall have full access for testing and servicing of the backflow preventer with strategically placed lockable access panels. Enclosure shall be anchored to a concrete pad within the enclosure with masonry anchors. Heat, when required (ASSE Class I), shall be a thermostatically controlled 120V/1PH fan forced heater. Heater shall be UL or ETL listed and sized to maintain +40°F inside the enclosure with an outside temperature of -30°F. Heater shall have a six-foot cord and plug for easy receptacle connection. Power source shall be a ground fault interrupter receptacle supplied and installed by others. Electrical power source shall be installed in accordance with all state and local codes.

MODEL NUMBER	ENCLOSURE DESCRIPTION	INSIDE DIMENSIONS			OUTSIDE DIMENSIONS			CONCRETE PAD DIMENSIONS			SHIPPING WEIGHT
BFP6-N	2 DOOR PANEL	102"L	38"W	56"H	105"L	41"W	58"H	117"L	53"W	6"T	385#
BFP6-NS	2 DOOR PANEL	120"L	38"W	56"H	123"L	41"W	58"H	135"L	53"W	6"T	400#
BFP6-O	2 DOOR PANEL	102"L	38"W	67"H	105"L	41"W	69"H	117"L	53"W	6"T	395#
BFP6-OT	2 DOOR PANEL	105"L	40"W	78"H	108"L	43"W	80"H	120"L	55"W	6"T	425#
BFP6-OS	2 DOOR PANEL	120"L	38"W	67"H	123"L	41"W	69"H	135"L	53"W	6"T	415#
BFP6-NA	2 DOOR PANEL	64"L	42"W	48"H	67"L	45"W	50"H	79"L	57"W	6"T	350#
BFP6-OA	2 DOOR PANEL	64"L	55"W	48"H	67"L	58"W	50"H	79"L	70"W	6"T	375#

SUBMITTAL DATA SHEET

(888) 345-6675

(501) 791-1800

Fax (501) 791-1801

www.aquashieldenclosures.com

BFP8 SERIES
8" IN-LINE VALVE

ENCLOSURE FEATURES

- Easy Access
- Removable Top and Panels
- Lockable for Vandal Protection
- Freeze Protection (-30F)
- No subassembly required
- Oversized Drains at Enclosure Grade
- Structurally Rigid Insulation
- Simple Installation
- Mounting Hardware Included



STANDARDS & CODES

- ASSE 1060
- ASTM B209
- OSHA 1910

PRODUCT MATERIALS

- .050 MILL FINISHED MARINE GRADE ALUMINUM
- POLYISOCYANURATE INSULATION 1.5" THICK (10.0 R- VALUE)

The backflow enclosure shall be ASSE 1060 certified and shall provide freeze and vandal protection for backflow preventers installed outside and above ground. Materials shall be (.050/18 ga.) mill finished aluminum bonded to a unicellular non-wicking polyisocyanurate foam core insulation. Insulation shall be 1.5" thick (R10) and have a heavy black reinforced fiber on each side. Drain shall be insulated and sized to accommodate maximum discharge of the backflow preventer valve and remain closed except during discharge of the backflow valve. The enclosure shall have full access for testing and servicing of the backflow preventer with strategically placed lockable access panels. Enclosure shall be anchored to a concrete pad within the enclosure with masonry anchors.

Heat, when required (ASSE Class I), shall be a thermostatically controlled 120V/1PH fan forced heater. Heater shall be UL or ETL listed and sized to maintain +40°F inside the enclosure with an outside temperature of -30°F. Heater shall have a six-foot cord and plug for easy receptacle connection. Power source shall be a ground fault interrupter receptacle supplied and installed by others. Electrical power source shall be installed in accordance with all state and local codes.

MODEL NUMBER	ENCLOSURE DESCRIPTION	INSIDE DIMENSIONS			OUTSIDE DIMENSIONS			CONCRETE PAD DIMENSIONS			SHIPPING WEIGHT
BFP8-N	2 DOOR PANEL	120"L	38"W	56"H	123"L	41"W	58"H	135"L	53"W	6"T	430#
BFP8-NS	4 DOOR PANEL	142"L	38"W	56"H	145"L	41"W	58"H	157"L	53"W	6"T	495#
BFP8-O	2 DOOR PANEL	120"L	38"W	78"H	123"L	41"W	80"H	135"L	53"W	6"T	500#
BFP8-OS	4 DOOR PANEL	142"L	38"W	78"H	145"L	41"W	80"H	157"L	53"W	6"T	545#
BFP8-NA	2 DOOR PANEL	74"L	47"W	54"H	77"L	50"W	56"H	89"L	62"W	6"T	340#
BFP8-NAT	2 DOOR PANEL	74"L	47"W	60"H	77"L	50"W	62"H	89"L	62"W	6"T	370#
BFP8-OA	2 DOOR PANEL	74"L	67"W	54"H	77"L	70"W	56"H	89"L	82"W	6"T	405#
BFP8-OAT	2 DOOR PANEL	74"L	67"W	60"H	77"L	70"W	62"H	89"L	82"W	6"T	445#

SUBMITTAL DATA SHEET
(888) 345-6675
(501) 791-1800
Fax (501) 791-1801
www.aquashieldenclosures.com

BFP10 SERIES
10" IN-LINE VALVE

- ENCLOSURE FEATURES**
- Easy Access
 - Removable Top and Panels
 - Lockable for Vandal Protection
 - Freeze Protection (-30F)
 - No subassembly required
 - Oversized Drains at Enclosure Grade
 - Structurally Rigid Insulation
 - Simple Installation
 - Mounting Hardware Included



- STANDARDS & CODES**
- ASSE 1060
 - ASTM B209
 - OSHA 1910

- PRODUCT MATERIALS**
- .050 MILL FINISHED MARINE GRADE ALUMINUM
 - POLYISOCYANURATE INSULATION 1.5" THICK (10.0 R- VALUE)

The backflow enclosure shall be ASSE 1060 certified and shall provide freeze and vandal protection for backflow preventers installed outside and above ground. Materials shall be (.050/18 ga.) mill finished aluminum bonded to a unicellular non-wicking polyisocyanurate foam core insulation. Insulation shall be 1.5" thick (R10) and have a heavy black reinforced fiber on each side. Drain shall be insulated and sized to accommodate maximum discharge of the backflow preventer valve and remain closed except during discharge of the backflow valve. The enclosure shall have full access for testing and servicing of the backflow preventer with strategically placed lockable access panels. Enclosure shall be anchored to a concrete pad within the enclosure with masonry anchors.

Heat, when required (ASSE Class I), shall be a thermostatically controlled 120V/1PH fan forced heater. Heater shall be UL or ETL listed and sized to maintain +40°F inside the enclosure with an outside temperature of -30°F. Heater shall have a six-foot cord and plug for easy receptacle connection. Power source shall be a ground fault interrupter receptacle supplied and installed by others. Electrical power source shall be installed in accordance with all state and local codes.

MODEL NUMBER	ENCLOSURE DESCRIPTION	INSIDE DIMENSIONS	OUTSIDE DIMENSIONS	CONCRETE PAD DIMENSIONS	SHIPPING WEIGHT
BFP10-N	4 DOOR PANEL	142"L 40"W 80"H	145" L 43" W 82"H	157"L 55"W 6"T	525#
BFP10-NS	4 DOOR PANEL	172"L 40"W 80"H	175"L 43"W 82"H	187"L 55"W 6"T	620#
BFP10-O	4 DOOR PANEL	142"L 40W 90"H	145"L 43"W 92"H	157"L 55"W 6"T	575#
BFP10-OS	4 DOOR PANEL	172" L 40"W 90"H	175"L 43"W 92"H	187"L 55"W 6"T	695#



Outdoor Enclosure Specifications Model BFP3-BFP10 Series

1 GENERAL

1.1 WORK INCLUDED

- A. Provide manufactured outdoor enclosure for backflow prevention assembly.

1.2 QUALITY ASSURANCE

- A. Qualifications: The manufacturer of the outdoor enclosure shall be a company specializing in the field of manufacturing of such enclosures with at least ten (10) years of successful field installations and be ASSE 1060 Seal certified.

1.3 REFERENCES

- A. ASSE 1060-Performance Requirements for Outdoor Enclosures for Backflow Prevention Assemblies.
B. ASTM B209

1.4 ACCEPTABLE MANUFACTURERS

- A. **AquaSHIELD** or Engineer approved equivalent.

2 PRODUCTS

2.1 MODEL NO. & SIZE

- A. Model No. shall be BFP__-__
B. Inside dimensions shall be __"L x __"W x __"H (+ or - 1/2")

2.2 MATERIALS OF FABRICATION

- A. Materials for exterior walls shall be 5052-H32 aluminum (.050/18 gauge) and shall comply with ASTM B209. The aluminum shall have a factory mill finish.
- B. Insulation shall be a closed cell polyisocyanurate foam core laminated to heavy black glass fiber reinforced facers on each side. The insulation shall have the following properties:
- R-Value – 10.0
 - Dimensional Stability - 2% Linear Change
 - Compressive Strength - 20 psi and 25 psi
 - Product Density - Nominal 2.0 pcf
 - Water Absorption - <1% By Volume
 - Service Temperature - (-100°F to +250°F)
 - Moisture Vapor Transmission - < One (1) Perm
 - Flame Spread - 25**
 - Insulation shall be 1.5" thick
- C. Adhesive shall be Hilti brand Product No. CA-3200 and shall have the following features:
- Bonds foam products
 - Water resistant bond
 - Stays resilient
 - Will not freeze
 - Freeze/thaw stable

2.3 COMPONENTS

- A. The roof, walls and access panels shall be constructed of 5052-H32 (.050/18 gauge) mill finish marine grade aluminum ASTM B209 outside with insulation 1.5" thick (10.0 "R" value) in the walls and access panels and 3" thick (20.0 "R" value) in the roof panel.
- B. The above components shall be securely bonded to form a composite panel.
- C. The exterior of the panels shall have a protective PVC masking to protect the finish. The protective masking shall be removed by the customer immediately after installation of the enclosure.
- D. The roof and wall panels shall be fastened together with self-tapping stainless steel screws through holes provided in panels.
- E. The roof panel shall be secured to the wall panels by stainless steel screws on the outside and security clips on the inside.
- F. Access panels shall be () total in number () per side and shall be 39"W x ___"H.
- G. Each access panel shall have factory installed locks with master keys provided.
- H. Drain relief panel for the enclosure shall be constructed of same said materials as wall panels and be located in one or more of the access panels.
- I. Drain relief panel shall have a stainless steel hinge and stainless steel spring as a positive means of closure after water discharge to prevent the intrusion of outside air, debris, and small animals.

2.4 HEATING EQUIPMENT (ASSE 1060 CLASS I - HEAT REQUIRED, CLASS II - OPTIONAL)

- A. Enclosure shall not offer freeze protection without installation of heating equipment designed and provided by the manufacturer.
- B. Heating equipment designed and provided by the manufacturer shall maintain a minimum internal temperature of +40°F with the external temperature of -30°F.
- C. Heater shall be ETL, UL, or CSA certified.
- D. Heating equipment shall be installed above the level of RPZ discharge.
- E. Electrical power source for heater shall be a designated circuit with G.F.I. protection and a minimum of 8" clearance from receptacle base to top of slab.

2.5 INSTALLATION HARDWARE

- A. Threaded fasteners shall be stainless steel and provided by the manufacturer.
- B. Concrete anchors shall be Hilti Hit type and provided by the manufacturer.
- C. Masonry drill bit and screw chuck shall be provided by the manufacturer.

2.6 INSTALLATION

- A. Recommended pad size shall be ___"L x ___"W x 6"T.
- B. Enclosure shall be assembled per manufacturer's instructions provided with enclosure.
- C. Enclosure shall be mounted to concrete pad per manufacturer's instructions.
- D. Enclosure shall be assembled plumb and square.

AquaSHIELD®

PROTECTIVE ENCLOSURES

INSTALLATION INSTRUCTIONS SERIES: BFP3, BFP4, BFP6, BFP8

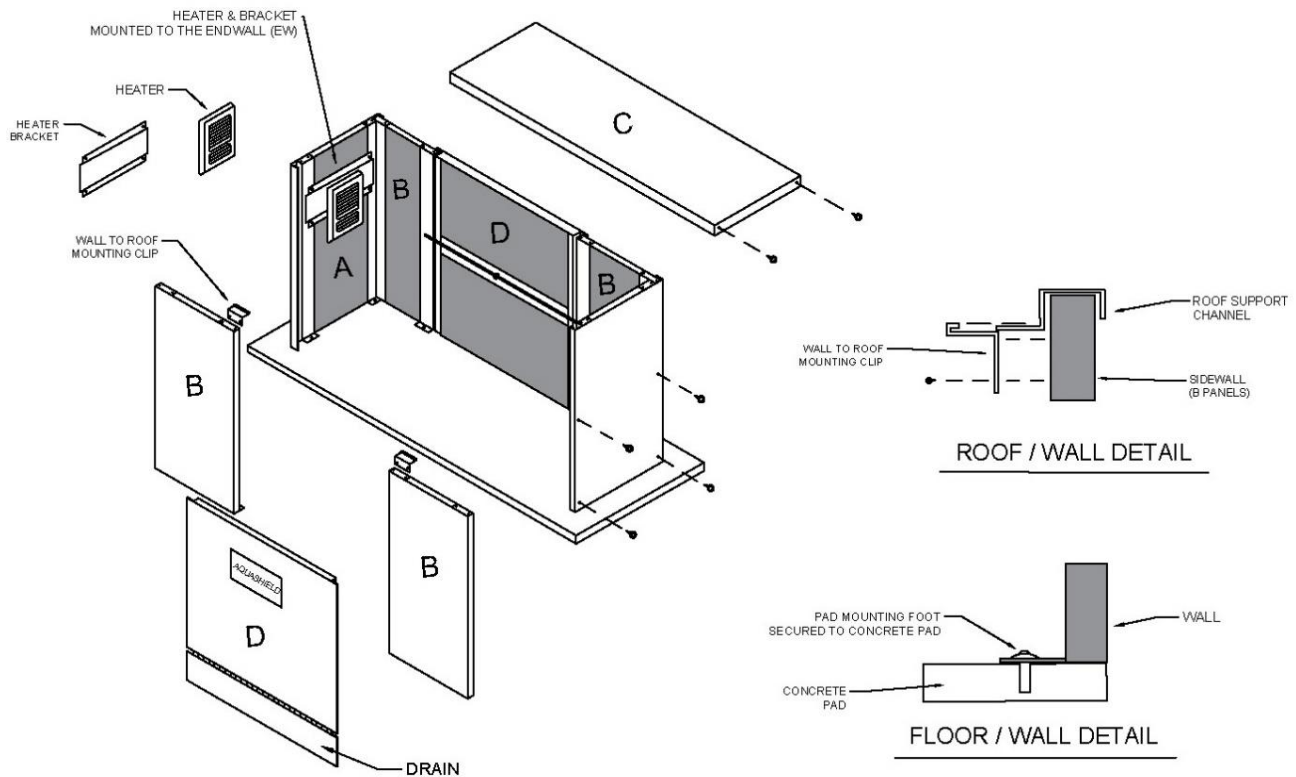

ENCLOSURE ASSEMBLY INSTRUCTIONS

1. Provide a 6" thick concrete mounting pad that measures 15" longer and 15" wider than the inside dimensions of the enclosure. Using the BFP as centerline, mark the outside dimensions (3" more than the inside dimensions) of the enclosure on the concrete pad.
2. Assemble end wall panel (A) and side wall panels (B) by sliding side walls into end wall and secure with self-tapping screws through holes provided in (A) panel. **Note: Pad mounting tabs on panels must be down for securing to pad.** Repeat with remaining (A) & (B) panels. Set assembled sections on marked pad centered around BFP devise.
3. Set roof panel (C) on assembled sections and fasten with self-tapping screws through holes provided at end of roof panel as shown.
4. **To insure proper fit of access panels (D), verify that the door openings measure 39" across the top and bottom and the walls are plumb.** Secure enclosure to pad with masonry anchors provided. (Floor/Wall Detail)
5. Attach the "wall to roof mounting clip" to roof and secure to support channels of (B) panels on each side of access openings. (Roof/Wall Detail)
6. If heater is provided, attach heater to "heater mounting bracket" located on end wall panel by using self-tapping screws through back of heater box. **Note: Provide ground GFI receptacle and Follow all governing electrical codes and regulations.**
7. Set access doors in place and lock.
8. Remove the protective plastic film from the enclosure. **Note: Failure to remove plastic from panels will cause damaged to the exterior finish of the enclosure**



MOUNTING PAD PREPARATION

SERIES: BFP3, BFP4, BFP6, BFP8

<i>MODEL NUMBER</i>	<i>ENCLOSURE DESCRIPTION</i>	<i>INSIDE DIMENSIONS</i>			<i>OUTSIDE DIMENSIONS</i>			<i>CONCRETE PAD DIMENSIONS</i>			<i>SHIPPING WEIGHT</i>
BFP3-N	2 DOOR PANEL	74"L	24"W	45"H	77"L	27"W	47"H	89"L	39"W	6"T	185#
BFP3-NS	2 DOOR PANEL	84"L	24"W	45"H	87"L	27"W	47"H	99"L	39"W	6"T	215#
BFP3-O	2 DOOR PANEL	74"L	24"W	57"H	77"L	27"W	57"H	89"L	39"W	6"T	215#
BFP3-OS	2 DOOR PANEL	84"L	24"W	55"H	87"L	27"W	57"H	99"L	39"W	6"T	225#
BFP4-N	2 DOOR PANEL	88"L	28"W	44"H	91"L	31" W	46"H	103"L	43"W	6"T	225#
BFP4-NS	2 DOOR PANEL	102"L	28"W	44"H	105"L	31"W	46"H	117"L	43"W	6"T	385#
BFP4-O	2 DOOR PANEL	88"L	28"W	54"H	91"L	31"W	56"H	103"L	43"W	6"T	435#
BFP4-OT	2 DOOR PANEL	95"L	40"W	64"H	98"L	43"W	66"H	110"L	55"W	6"T	450#
BFP4-OS	2 DOOR PANEL	102"L	28"W	54"H	105"L	31"W	56"H	117"L	43"W	6"T	450#
BFP4-NA	2 DOOR PANEL	55"L	35"W	45"H	58"L	38"W	48"H	70"L	50"W	6"T	290#
BFP4-OA	2 DOOR PANEL	55"L	45"W	45"H	58"L	48"W	48"H	70"L	60"W	6"T	315#
BFP6-N	2 DOOR PANEL	102"L	38"W	56"H	105"L	41" W	58"H	117"L	53"W	6"T	385#
BFP6-NS	2 DOOR PANEL	120"L	38"W	56"H	123"L	41"W	58"H	135"L	53"W	6"T	400#
BFP6-O	2 DOOR PANEL	102"L	38"W	67"H	105"L	41"W	69"H	117"L	53"W	6"T	395#
BFP6-OT	2 DOOR PANEL	105"L	40"W	78"H	108"L	43"W	80"H	120"L	55"W	6"T	425#
BFP6-OS	2 DOOR PANEL	120"L	38"W	67"H	123"L	41"W	69"H	135"L	53"W	6"T	415#
BFP6-NA	2 DOOR PANEL	64"L	42"W	48"H	67"L	45"W	50"H	79"L	57"W	6"T	350#
BFP6-OA	2 DOOR PANEL	64"L	55"W	48"H	67"L	58"W	50"H	79"L	70"W	6"T	375#
BFP8-N	2 DOOR PANEL	120"L	38"W	56"H	123"L	41" W	58"H	135"L	53"W	6"T	430#
BFP8-NS	4 DOOR PANEL	142"L	38"W	56"H	145"L	41"W	58"H	157"L	53"W	6"T	495#
BFP8-O	2 DOOR PANEL	120"L	38"W	78"H	123"L	41"W	80"H	135"L	53"W	6"T	500#
BFP8-OS	4 DOOR PANEL	142" L	38"W	78"H	145"L	41"W	80"H	157"L	53"W	6"T	545#
BFP8-NA	2 DOOR PANEL	74"L	47"W	54"H	77"L	50"W	56"H	89"L	62"W	6"T	340#
BFP8-NAT	2 DOOR PANEL	74"L	47"W	60"H	77"L	50"W	62"H	89"L	62"W	6"T	370#
BFP8-OA	2 DOOR PANEL	74"L	67"W	54"H	77"L	70"W	56"H	89"L	82"W	6"T	405#
BFP8-OAT	2 DOOR PANEL	74"L	67"W	60"H	77"L	70"W	62"H	89"L	82"W	6"T	445#

1. Using the chart above, provide a concrete pad 6" thick centered around the BFP device.
 - A. Provide expansion material around the BFP risers.
 - B. Place GFI receptacle in pad if heat is required, before concrete is poured.
 - C. Finish concrete level and smooth. Allow concrete to cure before setting enclosure.
 - D. Electrical power source must comply with all local and national codes

AquaSHIELD®

PROTECTIVE ENCLOSURES

INSTALLATION INSTRUCTIONS SERIES: BFP10

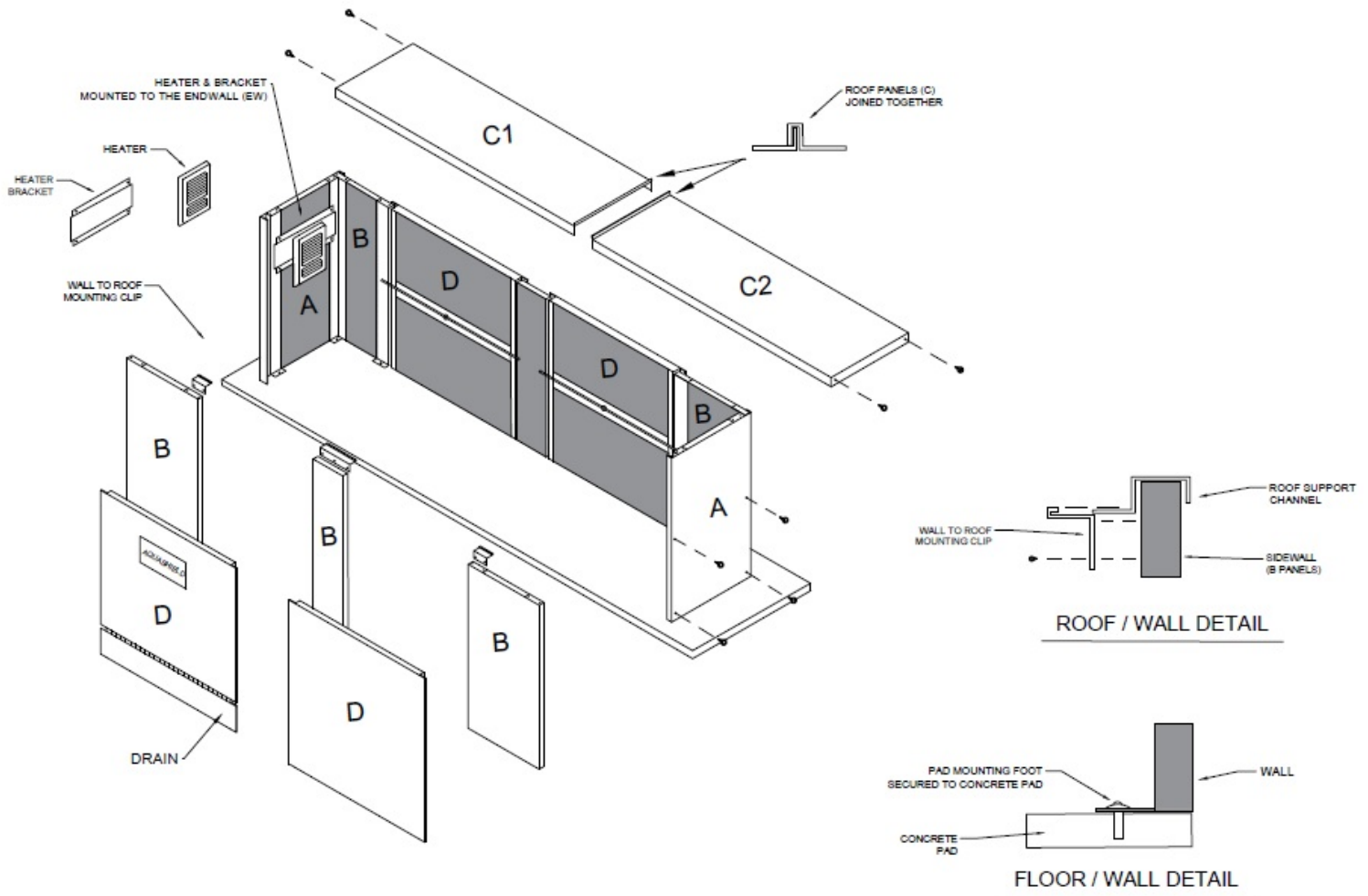

ENCLOSURE ASSEMBLY INSTRUCTIONS

1. Provide a concrete mounting pad according to the "Mounting Pad Preparation" sheet. Using the BFP as centerline, mark the outside dimensions of the enclosure on the concrete pad.
2. Assemble end wall panel (A) and side wall panels (B) by sliding side walls into end wall and secure with self-tapping screws through holes provided in (A) panel. **Note: Pad mounting tabs on panels must be down for securing to pad.** Repeat with remaining (A) & (B) panels. Set assembled sections on marked pad centered around BFP device.
3. Set roof panel (C1) & (C2) on assembled wall sections as shown. Fasten with screws through holes provided in the end of roof panels as shown. Temporarily set the center post in place to support the roof. Secure the roof together on the inside at the joint through the holes provided in the roof joint plate.
4. **To insure proper fit of access panels, verify that the door openings have the same dimensions across the top and bottom and the walls are plumb.** Secure enclosure to pad with masonry anchors provided. (FIG.1)
5. Attach "roof to wall mounting clips" to roof and screw to support channels on side walls at access openings and center post. (FIG.2)

6. If heater is provided, attach heater to “**heater mounting bracket**” located on end wall panel by using self-tapping screws through back of heater box. (FIG.3) **Note: Provide ground GFI receptacle and Follow all governing electrical codes and regulations.**
7. Set access doors in place and lock.
8. Remove the protective plastic film from the enclosure. **Note: Failure to remove plastic from panels will cause damaged to the exterior finish of the enclosure.**

MOUNTING PAD PREPARATION SERIES: BFP10

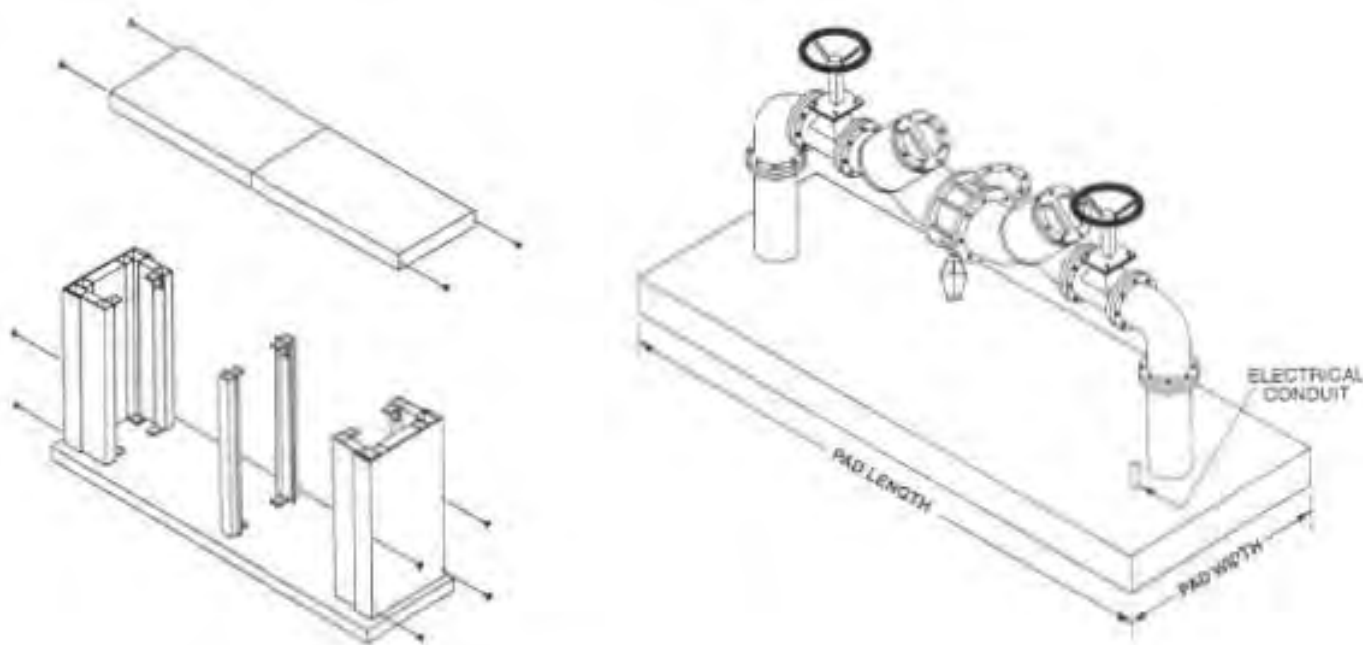

<i>MODEL NUMBER</i>	<i>ENCLOSURE DESCRIPTION</i>	<i>INSIDE DIMENSIONS</i>			<i>OUTSIDE DIMENSIONS</i>			<i>CONCRETE PAD DIMENSIONS</i>			<i>SHIPPING WEIGHT</i>
BFP10-N	4 DOOR PANEL	142"L	40"W	80"H	145"L	43"W	82"H	157"L	55"W	6"T	525#
BFP10-NS	4 DOOR PANEL	172"L	40"W	80"H	175"L	43"W	82"H	187"L	55"W	6"T	620#
BFP10-O	4 DOOR PANEL	142"L	40W	90"H	145"L	43"W	92"H	157"L	55"W	6"T	575#
BFP10-OS	4 DOOR PANEL	172" L	40"W	90"H	175"L	43"W	92"H	187"L	55"W	6"T	695#

1. Using the chart above, provide a concrete pad 6" thick centered around the BFP device.

- A. Provide expansion material around the BFP risers.
- B. Place GFI receptacle in pad if heat is required, before concrete is poured.
- C. Finish concrete level and smooth. Allow concrete to cure before setting enclosure.
- D. Electrical power source must comply with all local and national codes.

Section 3

3” to 10” N-Pattern Valve Enclosures

SUBMITTAL DATA SHEET
(888) 345-6675
(501) 791-1800
Fax (501) 791-1801
www.aquashieldenclosures.com

NBFP SERIES

N-PATTERN VALVE

ENCLOSURE FEATURES

- Easy Access
- Removable Top and Panels
- Lockable for Vandal Protection
- Freeze Protection (-30F)
- No subassembly required
- Oversized Drains at Enclosure Grade
- Structurally Rigid Insulation
- Simple Installation
- Mounting Hardware Included



STANDARDS & CODES

- ASSE 1060
- ASTM B209
- OSHA 1910

PRODUCT MATERIALS

- .050 MILL FINISHED MARINE GRADE ALUMINUM
- POLYISOCYANURATE INSULATION 1.5" THICK (10.0 R- VALUE)

The backflow enclosure shall be ASSE 1060 certified and shall provide freeze and vandal protection for backflow preventers installed outside and above ground. Materials shall be (.050/18 ga.) mill finished aluminum bonded to a unicellular non-wicking polyisocyanurate foam core insulation. Insulation shall be 1.5" thick (R10) and have a heavy black reinforced fiber on each side. Drain shall be insulated and sized to accommodate maximum discharge of the backflow preventer valve and remain closed except during discharge of the backflow valve. The enclosure shall have full access for testing and servicing of the backflow preventer with strategically placed lockable access panels. Enclosure shall be anchored to a concrete pad within the enclosure with masonry anchors.

Heat, when required (ASSE Class I), shall be a thermostatically controlled 120V/1PH fan forced heater. Heater shall be UL or ETL listed and sized to maintain +40°F inside the enclosure with an outside temperature of -30°F. Heater shall have a six-foot cord and plug for easy receptacle connection. Power source shall be a ground fault interrupter receptacle supplied and installed by others. Electrical power source shall be installed in accordance with all state and local codes.

MODEL NUMBER	ENCLOSURE DESCRIPTION	INSIDE DIMENSIONS			OUTSIDE DIMENSIONS			CONCRETE PAD DIMENSIONS			SHIPPING WEIGHT
NBFP4	2 DOOR PANEL	36"L	36"W	45"H	39" L	39" W	46"H	51"L	51"W	6"T	195#
NBFP6	2 DOOR PANEL	45"L	45"W	50"H	48"L	48"W	51"H	60"L	60"W	6"T	235#
NBFP8	2 DOOR PANEL	52"L	52"W	56"H	55"L	55"W	57"H	67"L	67"W	6"T	260#
NBFP10	2DOOR PANEL	52" L	65"W	56"H	55"L	68"W	57"H	67"L	80"W	6"T	295#



Outdoor Enclosure Specifications Model NBFP SERIES

1 GENERAL

1.1 WORK INCLUDED

- A. Provide manufactured outdoor enclosure for backflow prevention assembly.

1.2 QUALITY ASSURANCE

- A. Qualifications: The manufacturer of the outdoor enclosure shall be a company specializing in the field of manufacturing of such enclosures with at least ten (10) years of successful field installations and be ASSE 1060 Seal certified.

1.3 REFERENCES

- A. ASSE 1060-Performance Requirements for Outdoor Enclosures for Backflow Prevention Assemblies.
B. ASTM B209

1.4 ACCEPTABLE MANUFACTURERS

- A. **AquaSHIELD** or Engineer approved equivalent.

2 PRODUCTS

2.1 MODEL NO. & SIZE

- A. Model No. shall be NBFP__
B. Inside dimensions shall be __"L x __"W x __"H (+ or - 1/2")

2.2 MATERIALS OF FABRICATION

- A. Materials for exterior walls shall be 5052-H32 aluminum (.050/18 gauge) and shall comply with ASTM B209. The aluminum shall have a factory mill finish.
- B. Insulation shall be a closed cell polyisocyanurate foam core laminated to heavy black glass fiber reinforced facers on each side. The insulation shall have the following properties:
- R-Value – 10.0
 - Dimensional Stability - 2% Linear Change
 - Compressive Strength - 20 psi and 25 psi
 - Product Density - Nominal 2.0 pcf
 - Water Absorption - <1% By Volume
 - Service Temperature - (-100°F to +250°F)
 - Moisture Vapor Transmission - < One (1) Perm
 - Flame Spread - 25**
 - Insulation shall be 1.5" thick
- C. Adhesive shall be Hilti brand Product No. CA-3200 and shall have the following features:
- Bonds foam products
 - Water resistant bond
 - Stays resilient
 - Will not freeze
 - Freeze/thaw stable

2.3 COMPONENTS

- A. The roof, walls and access panels shall be constructed of 5052-H32 (.050/18 gauge) mill finish marine grade aluminum ASTMB B209 outside with insulation 1.5" thick (10.0 "R" value) in the walls and access panels and 3" thick (20.0 "R" value) in the roof panel.
- B. The above components shall be securely bonded to form a composite panel.
- C. The exterior of the panels shall have a protective PVC masking to protect the finish. The protective masking shall be removed by the customer immediately after installation of the enclosure.
- D. The roof and wall panels shall be fastened together with self-tapping stainless steel screws through holes provided in panels.
- E. The roof panel shall be secured to the wall panels by stainless steel screws on the outside and security clips on the inside.
- F. Access panels shall be (2) in number and shall be ___"W x ___"H.
- G. Each access panel shall have factory installed locks with master keys provided.
- H. Drain relief panel for the enclosure shall be constructed of same said materials as wall panels and be located in one or more of the access panels.
- I. Drain relief panel shall have a stainless steel hinge and stainless steel spring as a positive means of closure after water discharge to prevent the intrusion of outside air, debris, and small animals.

2.4 HEATING EQUIPMENT (ASSE 1060 CLASS I - HEAT REQUIRED, CLASS II - OPTIONAL)

- A. Enclosure shall not offer freeze protection without installation of heating equipment designed and provided by the manufacturer.
- B. Heating equipment designed and provided by the manufacturer shall maintain a minimum internal temperature of +40°F with the external temperature of -30°F.
- C. Heater shall be ETL, UL, or CSA certified.
- D. Heating equipment shall be installed above the level of RPZ discharge.
- E. Electrical power source for heater shall be a designated circuit with G.F.I. protection and a minimum of 8" clearance from receptacle base to top of slab.

2.5 INSTALLATION HARDWARE

- A. Threaded fasteners shall be stainless steel and provided by the manufacturer.
- B. Concrete anchors shall be Hilti Hit type and provided by the manufacturer.
- C. Masonry drill bit and screw chuck shall be provided by the manufacturer

2.6 INSTALLATION

- A. Recommended pad size shall be ___"L x ___"W x 6"T.
- B. Enclosure shall be assembled per manufacturer's instructions provided with enclosure.
- C. Enclosure shall be mounted to concrete pad per manufacturer's instructions.
- D. Enclosure shall be assembled plumb and square.

AquaSHIELD®

PROTECTIVE ENCLOSURES

INSTALLATION INSTRUCTIONS SERIES: NBF

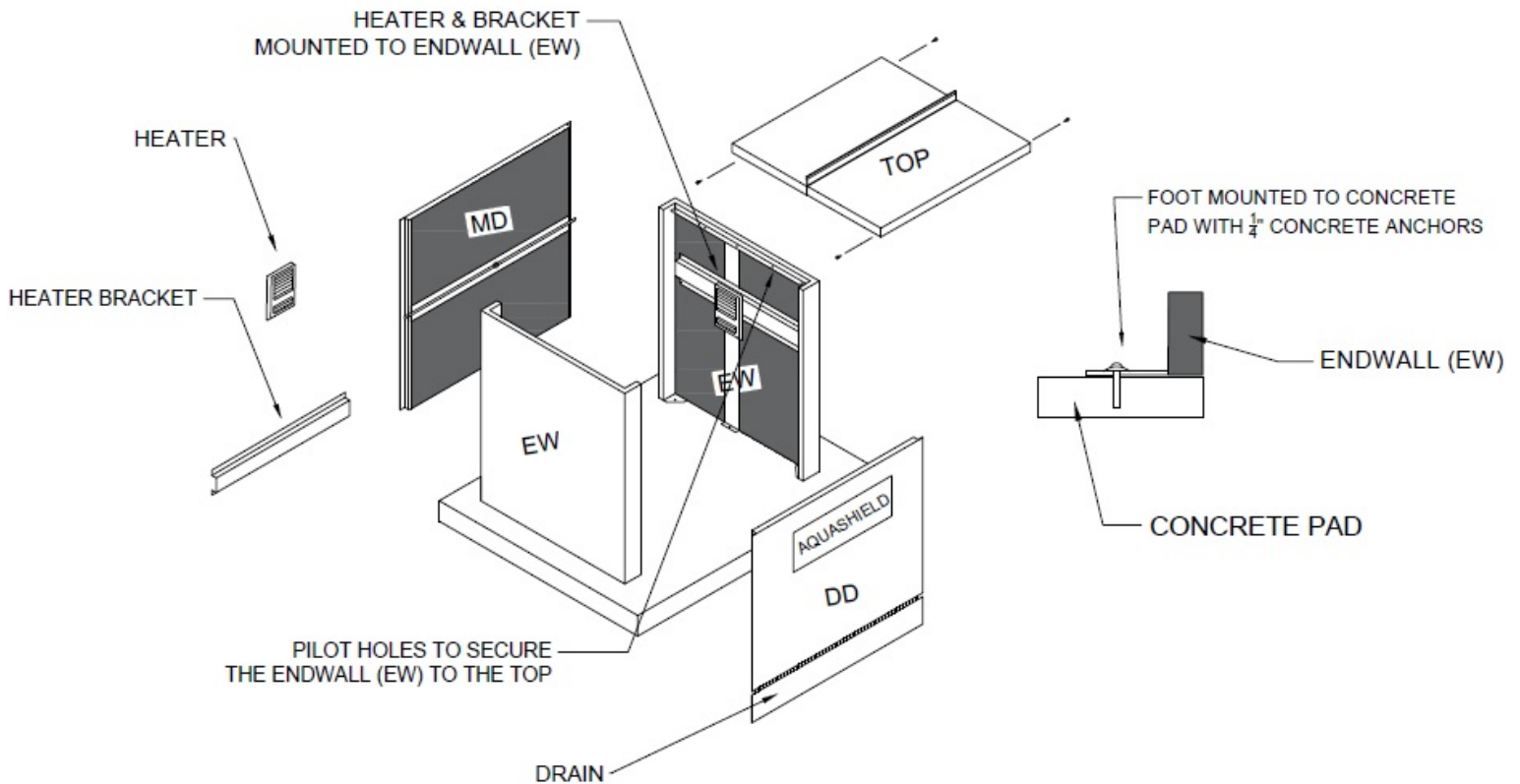

ENCLOSURE ASSEMBLY INSTRUCTIONS

1. Provide a concrete mounting pad according to the "Mounting Pad Preparation" sheet. Using the BFP as centerline, mark the outside dimensions of the enclosure on the concrete pad.
2. Set end wall panels on marked pad as shown.
3. Set roof panel (A) on side walls at opposite end of (#1) test cock. Secure with self-tapping screws on the inside of the enclosure through wall angle and underneath side of top. Set roof panel (B) with standing seam overlapping flange of (A) panel. (FIG1) Secure to side walls as before. **Note: Roof panel (B) must be located over #1 Test Cock for removal during testing.**
4. **To insure proper fit of access doors, verify that the side access openings have the same dimensions across the top and bottom and the walls are plumb.** Fasten enclosure to concrete pad through the holes provided in the corner mounting tabs attached to the walls.
5. If heater is provided, attach heater to "heater mounting bracket" by using self-tapping screws through the back of the heater box (FIG. 2). **Note: Install ground-fault circuit breaker and follow all governing electrical codes.**
6. Remove the protective plastic film from the enclosure. **Note: Failure to remove the plastic will cause damage to the exterior finish of the enclosure.**
7. Set access panels in place and lock.

MOUNTING PAD PREPARATION SERIES: NBFP'S

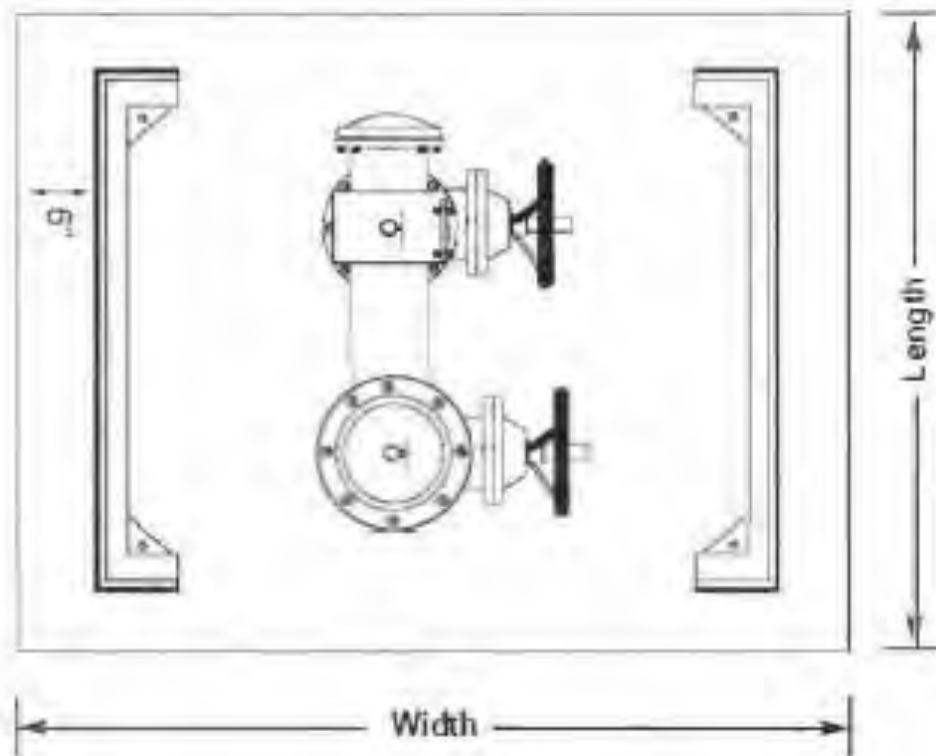

<i>MODEL NUMBER</i>	<i>ENCLOSURE DESCRIPTION</i>	<i>INSIDE DIMENSIONS</i>			<i>OUTSIDE DIMENSIONS</i>			<i>CONCRETE PAD DIMENSIONS</i>			<i>SHIPPING WEIGHT</i>
NBFP4	2 DOOR PANEL	36" L	36" W	45" H	39" L	39" W	46" H	51" L	51" W	6" T	195#
NBFP6	2 DOOR PANEL	45" L	45" W	50" H	48" L	48" W	51" H	60" L	60" W	6" T	235#
NBFP8	2 DOOR PANEL	52" L	52" W	56" H	55" L	55" W	57" H	67" L	67" W	6" T	260#
NBFP10	2DOOR PANEL	52" L	65" W	56" H	55" L	68" W	57" H	67" L	80" W	6" T	295#

1. Using the chart above, provide a concrete pad 6" thick centered around the BFP device.
 - A. Provide expansion material around the BFP risers.
 - B. Place GFI receptacle in pad if heat is required, before concrete is poured.
 - C. Finish concrete level and smooth. Allow concrete to cure before setting enclosure.
 - D. Electrical power source must comply with all local and national codes.

Section 4

Heaters / Heat Cables / Alarms

HEATER OPTION



- FEATURES: W FAN-FORCED
- 1000 watt and 1500 watt, 120 volt
- Smart Limit Protection® , UL listed , ASSE approved for wet and damp locations.
- Dual Open-Coil Element C-Frame Motor 4-Blade Aluminum Fan Quiet
- Inlet and outlet sensing
- 20 gauge powder-coated grille with contemporary die-formed round corners
- Heaters provide air movement at 85 CFM. Fan
- Motor is permanently lubricated, C-frame type with impedance protection and sealed bearings.
- It is equipped with a dynamically balanced four-blade aluminum impeller fan, located the upper portion of the heat box, and shall provide a down-flow heating pattern.
- Elements are constructed of coiled Nickel Chromium alloy, corrosion-resistant wire strung through a minimum of four rows of mica insulator.
- Thermal Overload: Heaters are equipped with thermal overload Smart Limit Protection®, which disconnects elements and motor in the event normal operating temperatures are exceeded. If thermal overload trips due to abnormal operating temperatures, thermal overload shall remain open until manually reset by turning the heater off for fifteen minutes.



Heat Systems Technology
Raychem quality design mean superior heating systems

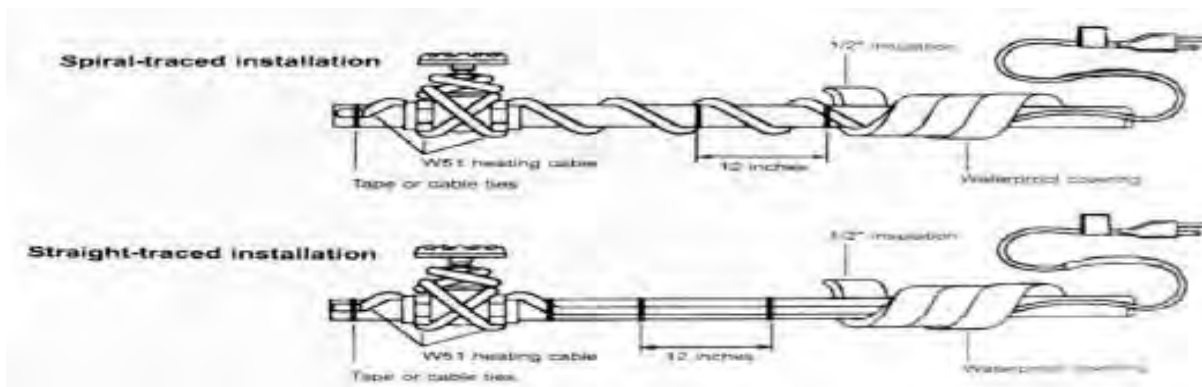

PRODUCT DATA

Guardian

W51-6P W51-12P
W51-18P W51-24P

Nominal service voltage:	120
Min. Power output at 40 degrees F:	5
Max circuit length (ft.):	n/a
Max circuit breaker size for	
- 40 degree F start-up (amps):	15
- 0 degree F start-up (amps):	15
Maximum exposure temp (F):	150

Use only in ordinary (nonhazardous) areas.
Do not expose to chemicals.

Approvals **

UL System Listed(1,2)

CSA Certified (3)

- (1) 60J9 Residential & Mobile Home Pipe Heating Cable
- (2) 718 K Pipe Heating Cable
- (3) C A fileLR21133

All information, including illustrations are believed to be reliable. Users, however, should independently evaluate the suitability of each product for their application. Raychem makes no warranties as to the accuracy or completeness of the information and disclaims any liability regarding its use. Raychem's only obligations are those in the Raychem standard Terms and Conditions of Sale of this product, and in no case will Raychem be liable for any incidental, indirect, or consequential damages arising from the sale, resale, use or misuse of this product. Specifications are subject to change without notice. Raychem reserves the right to make changes without notification to the buyer- to materials or processing that do not affect compliance with any applicable specification.

❖ SELF-REGULATION

The self-regulating design of HeatSystems heating cables eliminates worry about overheating or burnouts from overlapping. The conductive polymer core automatically adjusts heat output at each point along the pipe, with no need for thermostats.

❖ PARALLEL CIRCUITRY

Unlike conventional heating cables, Raychem heating cables feature parallel circuitry. This means you can cut it at any point along its length without interrupting the heating-cable circuit.

❖ PROVEN ADVANTAGES FOR YOU

Fast, easy to install. Thanks to their self-regulating, parallel-circuit design, HeatSystems heating cables require no complex installation procedures. They can be straight-traced, spiraled or overlapped. On the job, you can cut them to the exact length needed and splice or tee them, adapting each heating-cable circuit as the job requires.

Reliable performance. Because they're self-regulating, HeatSystems require no thermostat, so you're not bothered by breakdown or call backs.

Convenient and economical. For larger jobs, you can simply cut the exact amount of HeatSystems heating cable you need right from the reel.

Designed flexibility. Hardwire them or plug them in. With two options of power connections kits, the choice is yours. There is even a preassembled heating cable available in convenient lengths to handle small jobs fast.

Safe on plastic pipes. HeatSystems heating cables can be used on plastic and metal pipes. Their self-regulating heating core adjusts automatically, to protect against overheating or developing hot spots when overlapped or covered with insulation.

Energy-efficient The self-regulating core generates heat when and where it's needed. The core continuously adjust its heat output to the environment at every point along the cable.

Raychem Distributed by AquaSHIELD®

TA2 Temperature Alarm



Single Setting Temperature Alarm, Adjustment from -10 to 80 Degrees Fahrenheit, Alarm On Temperature Rise Or Temperature Fall, Power 120 VAC, Power Cord 6 Foot, Audible Buzzer, Remote Connection Rater 120 Volts AC 5 Amps, Sensor Encapsulated With 6 Foot Cord

Indoor Temperature Alarms: Temperature alarms signal temperature fluctuations. Probe wire can be cut in field and extended up to 200 ft. (Nos. 3T186 and 4J260) or 100 ft. (No. 4J261) using 22-ga speaker wire.

Uses: Freezers, refrigerators, greenhouses, and tropical aquariums. Alarms adjust from -10 Degree to 80 Degree F Includes encapsulated thermistor temperature probe Slide switch between no delay and 1 hour delay Built-in audible alarm

Single Setting AC Alarm: Alarms on rise or fall in temperature Remote alarm dry contacts 120VAC/5 amps Light flashes for 1 hour

Tech Specs

Item: Temperature Alarm

Type: Single Setting

Temp. Range (F): -10 to 80

Time Delay: 0 or 1 Hr, User Selectable

Contact Rating @ 120V (A): 5

Alarm Setting: Activate on Temp Rise or Fall

Indication: Audible and Visual

Power Source: 120V AC

Height (In.): 4 7/8

Width (In.): 3

Depth (In.): 1 5/8

Sensor Lead: Can be Extended Up to 200 Ft

Probe Length (In.): 72

Includes: Instructions

Warranty Length: 1 Year



**LED Light, Depth 5 1/8 In,
Voltage 120 Red**

LED Warning Light, Steady Burn, Dia. 3 1/8 In, Depth 5 1/8 In, Lamp Life 100,000 Hours, 8.2 Candle Power, Voltage 120 VAC, 0.13 Amps AC, 15.6 Watts, Neoprene Rubber Gasket, Lens Design Fresnel, Lens Material Polycarbonate, Glass Filled Polycarbonate Housing Material, Tee Surface Mounting, Type 4X Rating, Operating Temp -31 to 150 F, Color Red, UL, cUL, CSA Standards, Includes Gasket

**Warning Lights and Mounting Kit
UL Listed and CSA Certified
LED Steady Burn**

(I) Streamline(R) Low Profile LED

Compact design for use in a variety of signaling applications.
Available in 3 mounting configurations. NEMA 4X.

Tech Specs

Item: LED Warning Light

Type: Steady Burn **Color:** Red

Height (In.): 3 1/8

Dia. (In.): 5

Depth (In.): 5 1/8

Lamp Life (Hours): 100,000

Candle Power: 8.2

Voltage: 120VAC

Amps AC: 0.13

Watts: 15.6

Gasket: Neoprene Rubber

Lens Design: Fresnel

Lens Material: Polycarbonate

Housing Material: Glass Filled Polycarbonate

Mounting: Surface

Rating: Type 4X

Operating Temp. (F): -31 to 150

Standards: UL, cUL, CSA

Includes: Gasket

Notes & Restrictions Note: FPM: Flashes per minute.

Wet Location Light



Industrial Fluorescent Fixture is designed for low to medium mounting heights and is ideal for use in areas of dirt, dust, humidity and moisture. The fixture features a UV-stabilized, impact-resistant, clear prismatic polycarbonate lens in a fully gasketed housing.

- Acrylic housing is UL and wet-location listed
- Clear prismatic polycarbonate lens is UV stabilized and impact-resistant
- 2 stainless steel mounting brackets allow for flush mount
- Fully gasketed housing is sealed against dust, moisture, fumes and insects
- Uses two 32-Watt T8 fluorescent bulbs
- CUL listed to US and Canadian safety standards and wet location listed for covered ceiling applications

Length—51”

Width—7”

Height—5”

Depth —5.75”



Heater Sizing/ Standard Enclosures for Conventional In-Line Valves

Enclosure Model #	Watts / Heat Type	Volts	Amp	Phase
BFP1-S	30 W Heat Cable	120v	5	1
BFP2-S	60 W Heat Cable	120v	5	1
BFP3-N, NS	1000 W Heater	120V	8.33	1
BFP3-O, OS	1000 W Heater	120V	8.33	1
BFP4-NA, OA	1000 W Heater	120V	8.33	1
BFP4-N, O	1500 W Heater	120V	12.5	1
BFP4-OS, OT	1500 W Heater	120V	12.5	1
BFP6-NA, OA	1500 W Heater	120V	12.5	1
BFP6-O, OS, OT	(2)1500 W Heater	120V	12.5	1
BFP6-N, NS	(2)1500 W Heater	120V	12.5	1
BFP8-N, NS	(2)1500 W Heater	120V	12.5	1
BFP8-NA, NAT, OA, OAT	(2) 1000 W Heater	120V	8.33	1
BFP8-O, OS	(2) 1500 W Heater	120V	12.5	1
BFP10-N	(2) 1500 W Heater	120V	12.5	1
BFP10-N-S	(2) 1500 W Heater	120V	12.5	1
BFP10-O	(2) 1500 W Heater	120V	12.5	1
BFP10-O-S	(2) 1500 W Heater	120V	12.5	1

Heater Sizing/ Standard Enclosures for N-Pattern Valves

Enclosure Model #	Watts / Heat Type	Volts	Amp	Phase
NBFP4	1000 W Heater	120V	8.33	1
NBFP6	1500 W Heater	120V	12.5	1
NBFP8	1500 W Heater	120V	12.5	1
NBFP10	(2)1000 W Heater	120V	8.33	1

* Wattage required to maintain an internal temperature of +40°F with an external temperature of -30 °F.

* Heat loss based on 15 m.p.h. wind speed.

Section 5

Miscellaneous



Date: January 5, 2018

To: All Concerned

Remit: *AquaSHIELD* Enclosures

Dear Customer,

AquaSHIELD Enclosures are produced in North Little Rock, AR with components made in the USA. We meet all requirements and are ARRA compliant.

Best Regards,

AquaSHIELD Management

American Society of Sanitary Engineering
FOR PLUMBING AND SANITARY RESEARCH



This certifies that Aqua Shield is authorized to display the ASSE Seal on its

Product: **Outdoor Enclosures for Backflow Prevention Assemblies**

Model: **BFP1-S through BFP10-0-S & NBFPP4-N, NBFPP4-0, NBFPP6-N,**

Description: **NBFPP6-0, NBFPP8-N, NBFPP8-0, NBFPP10-N, NBFPP10-0** File#: 904

in the manner and under the conditions stated herein and any supplemental description sheets, in accordance with

ASSE Standard Number 1060-1996 Testing Laboratory Wyle Labs

This authorization is issued for one (1) year from date hereon and is renewable annually or until such time as the standard has been revised. Display of the ASSE Certification Mark(s)/seal(s) is not a product endorsement. Display of the ASSE Certification Mark(s) (seal/s) is confirmation that the product has been submitted to an ASSE listed independent laboratory for compliance to the applicable product performance standard/s, reviewed by the voting members of the Seal Control Board and found to be in compliance with the applicable product performance standard/s.

The American Society of Sanitary Engineering has created the Seal Listing Program to encourage improvements in plumbing products and systems in the interests of greater protection of public health and safety.

Date October 25, 2001 Chairman Michael P. Pappas
ASSE Seal Control Board Chairman



**DRAIN OPENING SIZES AND CALCULATIONS FOR AQUASHIELD ENCLOSURES
MODELS BFP1-S - BFP10-OS**

ENCLOSURE MODEL NUMBER	DRAIN OPENING DIMENSIONS	DRAIN OPENING SQ. INCHES	DRAIN CAPACITY GALLONS PER MIN.	ASSE 1060 REQUIREMENT GALLONS PER MIN.
BFP1-S	6" X 18"	108	749	200
BFP2-2	6" X 34"	204	1415	300
BFP3-N	6" X 39"	234	1373	450
BFP3-NS	6" X 39"	234	1373	450
BFP3-O	6" X 39"	234	1373	450
BFP3-OS	6" X 39"	234	1373	450
BFP4-N	6" X 39"	234	1373	750
BFP4-NS	6" X 39"	234	1373	750
BFP4-O	6" X 39"	234	1373	750
BFP4-OS	6" X 39"	234	1373	750
BFP6-N	6" X 39"	234	1373	750
BFP6-NS	6" X 39"	234	1373	750
BFP6-O	6" X 39"	234	1373	750
BFP6-OS	6" X 39"	234	1373	750
BFP8-N	6" X 39"	234	1373	1100
BFP8-NS	6" X 39"	234	1373	1100
BFP8-O	6" X 39"	234	1373	1100
BFP8-OS	6" X 39"	234	1373	1100
BFP10-N	6" X 39"	234	1373	1100
BFP10-NS	6" X 39"	234	1373	1100
BFP10-O	6" X 39"	234	1373	1100
BFP10-OS	6" X 39"	234	1373	1100

**DRAIN OPENING SIZES AND CALCULATIONS FOR AQUASHIELD ENCLOSURES
MODELS NBFP4 - NBFP10**

ENCLOSURE MODEL NUMBER	DRAIN OPENING DIMENSIONS	DRAIN OPENING SQ. INCHES	DRAIN CAPACITY GALLONS PER MIN.	ASSE 1060 REQUIREMENT GALLONS PER MIN.
NBFP4-N	6" X 23"	138	957	750
NBFP4-O	6" X 27"	162	1123	750
NBFP6-N	6" X 27"	162	1123	750
NBFP6-O	6" X 35"	210	1456	750
NBFP8-N	6" X 35"	210	1456	1100
NBFP8-O	6" X 45"	270	1872	1100
NBFP10-N	6" X 39"	234	1623	1100
NBFP10-O	6" X 55"	330	2289	1100

* Standard requirement is based on the ASSE Standard 1060 for Outdoor Enclosures.



TERMS AND CONDITIONS

TERMS: Net 30 days. Service charge of 1.5% per month on all past due accounts.

F.O.B. POINTS AND FREIGHTS: All sales are made F.O.B. Factory (No. Little Rock)) Arkansas with no freight allowances. Title passes to buyer as goods are received by the carrier. Buyer is responsible for all freight claims.

CANCELLATION OF ORDERS: Cancellation request must be received at the Factory before the order is shipped.

NON-STANDARD ITEMS: Non-standard OR custom items cannot be canceled or returned.

LIABILITY: AquaSHIELD® will not accept cost for field labor or materials to alter, change, or correct any product, unless written authorization has been issued by AquaSHIELD® prior to work being performed.

RETURNED GOODS: AquaSHIELD® products will not be accepted without written authorization from the factory. Returned Goods must be in their original packaging and be in First Quality Condition. AquaSHIELD® has the right after receiving Returned Products, to inspect the product for determination if the product is in First Quality Condition. Upon completion of inspection, if product damage is found, AquaSHIELD® will notify the customer of damages and estimated cost to repair the product to First Quality Condition. Customer may agree to pay cost of repair or request for the return of the product freight collect. No credit will be issued until payment for repair is received. Customer may not credit the original invoice for damage repair. All credits will be applied to future orders only.

LIMITED WARRANTY

THE ENCLOSURE IS NOT DESIGNED TO PREVENT FREEZING OF ANY COVERED EQUIPMENT WITHOUT A HEAT SOURCE DESIGNED AND PROVIDED BY AQUASHIELD. AquaSHIELD warrants for a period of (1) year from date of purchase that the product is free from defects in materials and workmanship (excluding the electrical equipment or electrical components of any heating device purchased with the enclosure). The electrical equipment and electrical components of any heating device purchased with the enclosure are warranted for a period of ninety (90) days to be free from defects in materials and workmanship. Aqua Shield's sole obligation and liability under the foregoing limited warranties (and the sole and exclusive remedy for the buyer for breach of the foregoing warranties) shall be the repair or replacement of the enclosure and any heating device purchased with the enclosure. Aqua Shield in its sole discretion, shall determine whether to repair or replace any defective material or work. Any such repair or replacement shall be performed by AquaSHIELD. The foregoing limited warranties are given in lieu of all other warranties, expressed or implied, INCLUDING WITHOUT LIMITATION THE WARRANTY OF MERCHANTABILITY OR THE WARRANTY FOR THE FITNESS FOR A PARTICULAR PURPOSE.

IN NO EVENT WHATSOEVER SHALL AQUASHIELD BE LIABLE FOR ANY PROPERTY DAMAGE OR INCIDENTAL OR CONSEQUENTIAL DAMAGE, including but not limited to lost profits, lost rents or lost use. The foregoing limitations on liability apply regardless of whether the claim for property damage or incidental or consequential damage is based on breach of contract, negligence, strict liability or any other legal theory.



OPERATIONS & MAINTENANCE SCHEDULE

The AquaSHIELD enclosure is designed for minimum maintenance. Areas that need to be checked at the beginning of each cold season are:

- **Heater**
 - Insure that power is supplied to heater.
 - Check correct operation of the heater: that it turns on and the air blows hot. (Note: An ice cube on the thermostat sensor bulb works great)
 - Adjustable thermostats should be set to 40°F.

- **Enclosure**
 - Visually inspect the unit for physical damage
 - Insure all locks and latches are lubricated and secure.

- **Accessories**
 - Check operation of any accessories.